



Masonry Advisory Council

MASONRY ADVISORY COUNCIL

1480 Renaissance Drive, Suite 302 Park Ridge, IL 60068

Telephone : 847-297-6704 Fax : 847-297-8373

Web : www.MacOnline.org Email: Info@MacOnline.org

November, 2003

To: Architects, Engineers, Builder Developers / Contractors / Owners

From: Charles Ostrander, P.E. Executive Director of the Illinois Masonry Institute

RE: Ramblings Part 3

CRACK CONTROL IN 4" CONCRETE MASONRY VENEERS

The introduction of a Concrete Masonry banding in a clay brick veneer wall is a popular design element, as it is for using concrete masonry veneers for entire walls. Using 4" split face units, ground faced units, glazed block, half high concrete masonry units or simulated stone units made of concrete are all commonly used as a banding course or courses within a brick wall. These concrete masonry bandings can be used successfully without cracking problems if designed and built properly. This holds true whether the backup wall is made of concrete masonry or stud backup.

The following items must be included on the project drawings:

- Additional ladder joint reinforcing placed @ 16" vertically in just the exterior wythe of the concrete masonry banding units
- Vertical control joints in the concrete masonry banding spaced at a maximum of 20' on center.

If you are using these units in a veneer wall, you have to use the code required anchors at the designated spacing. The additional ladder reinforcing in the 4" exterior CMU is not code mandated, but if you wish to minimize shrinkage cracking - you better call out and show this additional joint reinforcement on the drawings. The minimal cost is certainly worth the quality finished product.

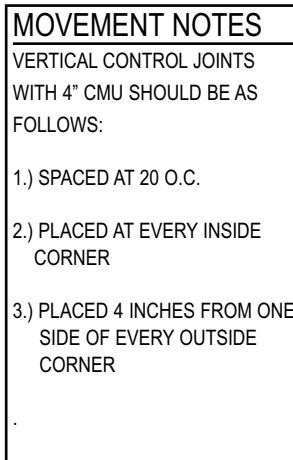
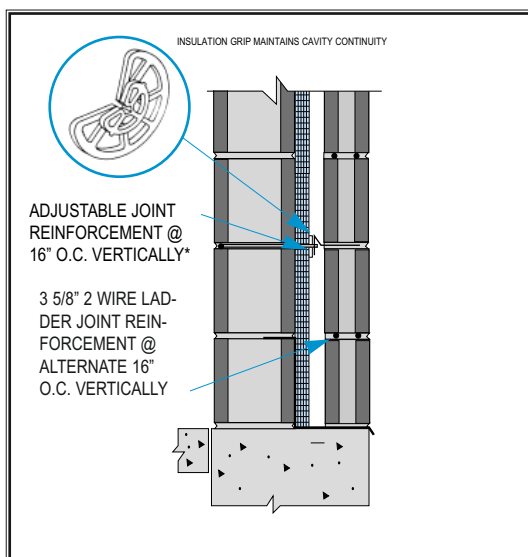

* All joint reinforcement should be hot-dipped galvanized

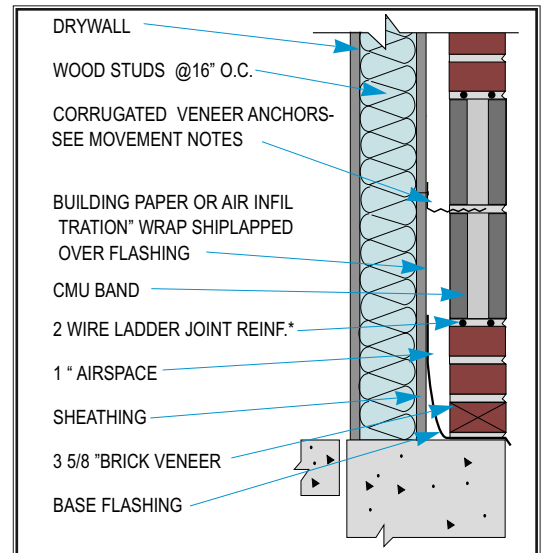

{over}

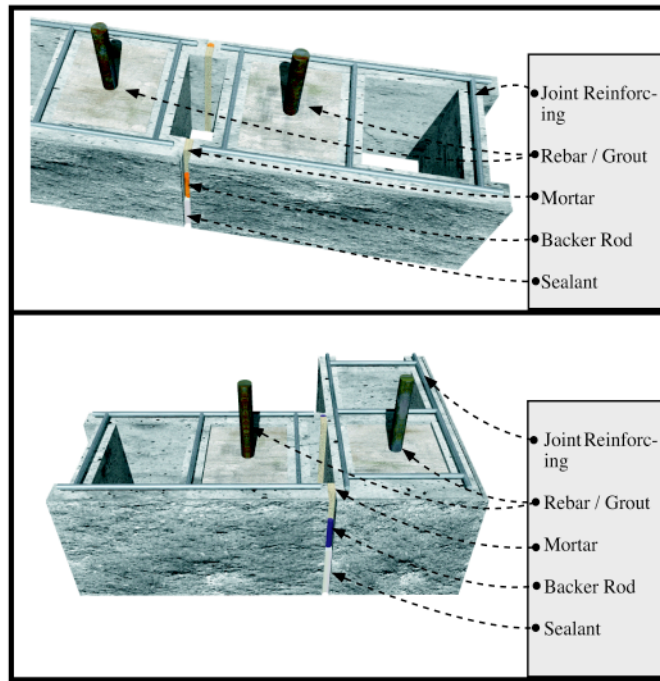

Control Joint Details

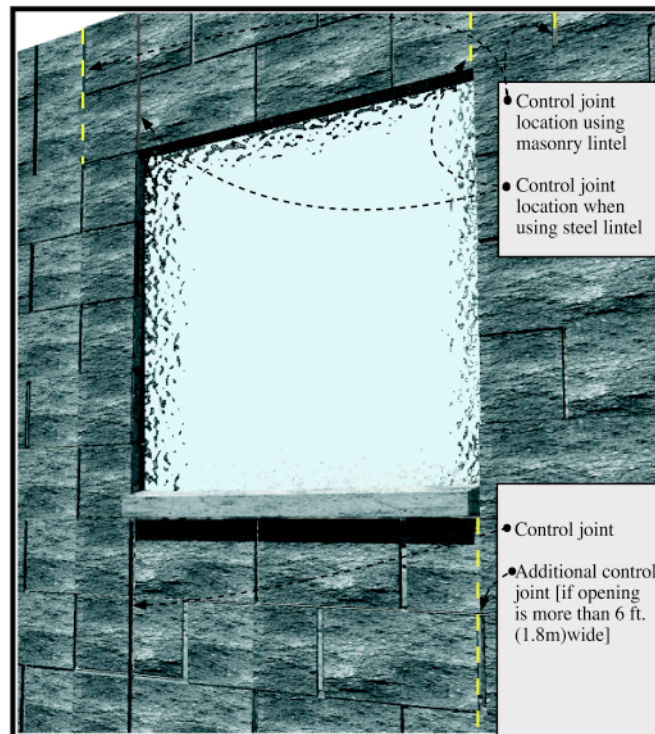

Control Joint at Opening