

# SELF-SUPPORTING BRICK

## WITHOUT STEEL SHELF ANGLES

BY CHARLES OSTRANDER, PE

Cavity walls have been successfully used in mid-rise and high-rise construction. Buildings in excess of 40 stories have utilized cavity walls with a structural reinforced concrete frame.

There are two methods of support for cavity walls cladded to concrete frame structures. One is by means of shelf angles; the other is to bear the total wall directly on the outer slab edge. Each system has advantages and disadvantages.

Shelf angles create a continuous horizontal break within the cavity, obstructing the vertical flow of moisture through the air space. If special attention is not given to the detailing and installation of shelf angles, moisture infiltration, efflorescence and brick spalling can occur. A reduction of shelf angles will also eliminate the number of horizontal expansion joints required. The further apart the expansion joints are spaced, the wider the joint needs to be. Most horizontal expansion joints need to be initially  $\frac{3}{4}$ " to 1" wide. After differential movement occurs, the joint will compress to approximately  $\frac{3}{8}$ "– $\frac{3}{4}$ ". The width of an expansion joint is based upon the desired width of the joint, its spacing, the compressibility of the sealant selected, the thermal and moisture expansion of the brick, and frame shortening.

An alternative method of design is to remove all shelf angles and bear the cavity wall on the floor slab edge. This eliminates the potential problems inherent with shelf angle design. Today, however, thermal bridging through the exposed edge of the concrete slab makes this type of system dated and less energy efficient.

Exposed slabs are susceptible to moisture infiltration at the cavity wall base. Special details must be developed to prevent wind-driven rain from penetrating beneath the flashing and into the building. Flashing must be set in a continuous bed of mastic, or a self-adhering flashing with stainless steel drip edges must be used to prevent wind-driven rain from penetrating beneath the flashing.

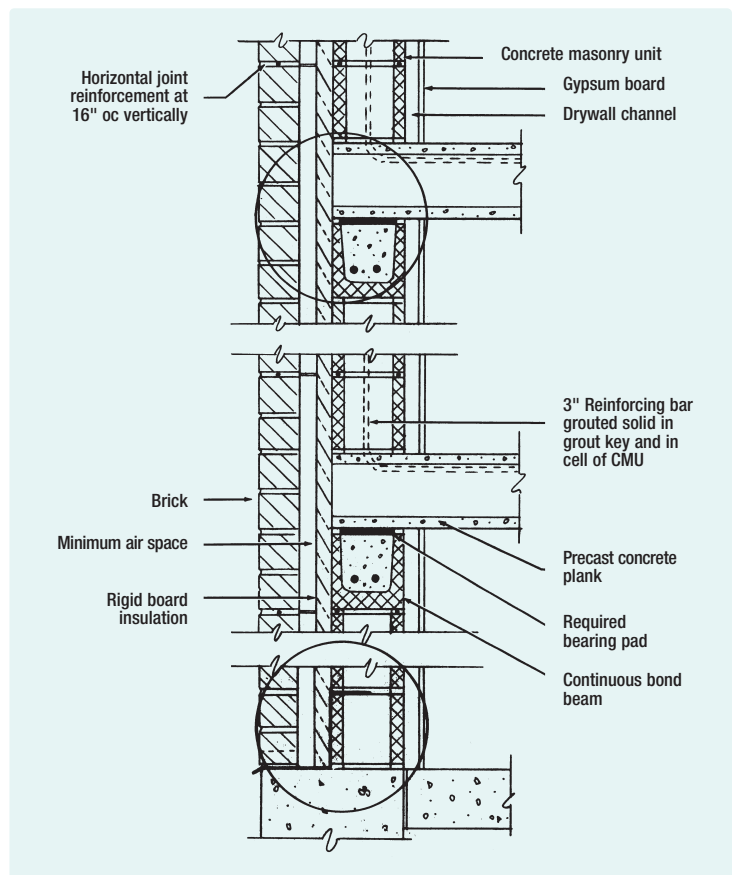

Typical bearing wall section

A hybrid use of brick with loadbearing concrete masonry backup or brick as a veneer bypassing a cast-in-place concrete wall has been used extensively for some time. Within the last couple of years, many knowledgeable architects and structural engineers have eliminated steel shelf angles by designing the brick to be self-supporting from the foundation to the top of the building. Before such a design application of brick is considered for use in a project, a number of caveats must be followed:

1. Brick should be self-supported by the concrete foundation walls.
2. Backup necessitates the use of noncombustible type of construction whether cast in place, hollow-core precast concrete wall panels



95' self-supported brick veneer, Tribune Freedom Press Tower, Chicago

## SELF-SUPPORTING BRICK

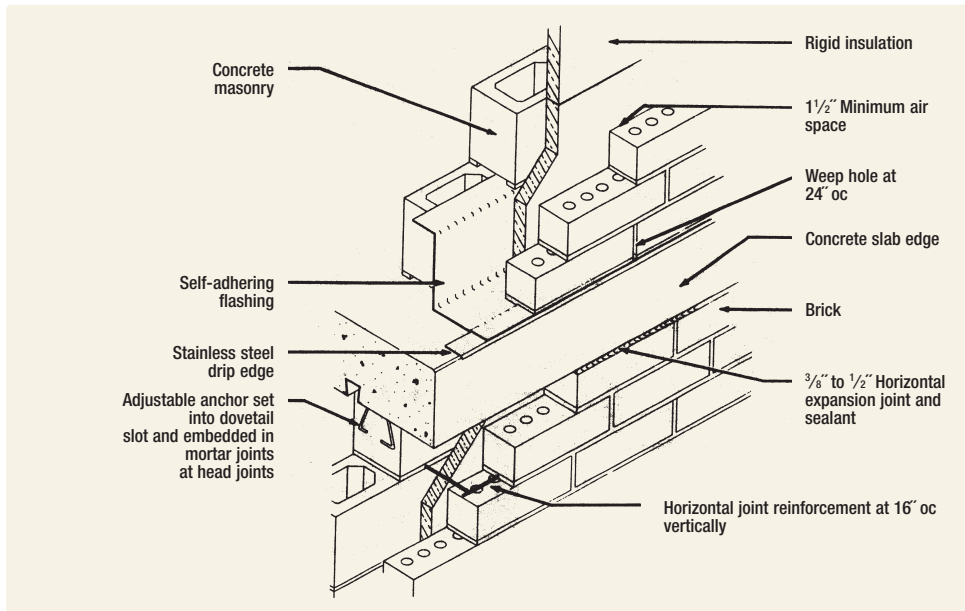

“Old,” exposed slab edge detail

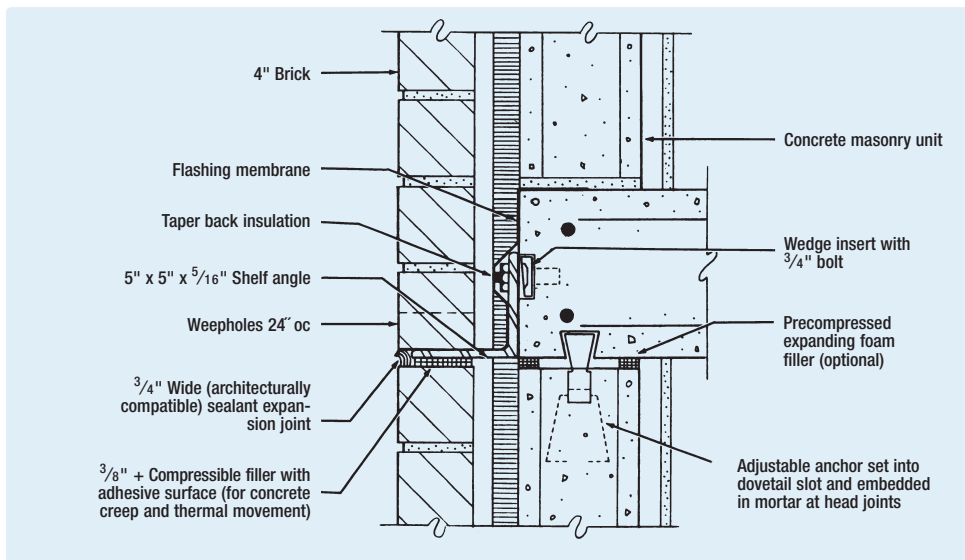

Shelf angle detail at 30', or every three typical floors

(with veneer dovetail slots cast into its exterior at 16" oc) or concrete block masonry used as infill between the structural members and floors of the exterior loadbearing wall system.

3. You can't have arbitrarily large or nonrepetitive window spacing in an elevation. These cause larger, irregularly concentrated loads supported by the brick veneer. The use of adjustable, hot-dipped joint reinforcing or adjustable hot-dipped ties is necessary to provide for the additional thermal and moisture movements that will occur on the exterior wythe during annual heating and cooling seasons.
4. When limited windows are used in the exterior of the building, the windows must be anchored to the concrete block masonry backup system, not to the brick veneer. Also, at least a  $\frac{3}{8}$ " to  $\frac{1}{2}$ " expansion



joint should be detailed all the way around the enclosed windows. A number of projects have used this application successfully.

5. Vertical expansion joints of  $\frac{3}{8}$ " to  $\frac{1}{2}$ " width at 30'-0" oc are also recommended.
6. The cap of the building must also allow the anticipated brick vertical movement.

With the above being said, another issue is that people will arbitrarily try to apply this system to a brick veneer/steel stud system. The concern here is that in a fire situation, even though steel studs are considered noncombustible, they can melt. As part of the structural and lateral support for the brick veneer, a melted and deformed steel stud/brick veneer system could cause additional structural problems and life safety concerns for the firefighters and public, from falling masonry. The structural stability and integrity of self-supporting brick must be maintained. Therefore, using shelf angles at every floor is recommended for use with steel stud/brick veneer exterior wall systems. Multi-story fire testing with brick veneer and steel studs is limited.

Another concern when using a self-supporting brick veneer from the foundation up is if the building occupancy changes or the use of the building is revised, the structural engineer of record on the newer structure should definitely be aware of the fact that greater care will have to be exercised in cutting or removing some of the exterior façade for potential alternatives due to the design using the self-supporting brick veneer system.

Shown here are some applications and wall cross-sectional details for consideration if the above criteria are too restrictive (the required size of expansion joints are too large) for the building that you are designing. Consider using a shelf angle at every two or three floors with a large enough horizontal soft joint underneath the angles to avoid distress due to frame shrinkage (creep) and masonry's thermal expansion. It's important that the drainage plane and the flashing and weepholes are installed properly with end dams. **ME**